

SOUSTRUHY

MULTIFUNKČNÍ SOUSTRUŽNICKO-FRÉZOVACÍ CENTRA

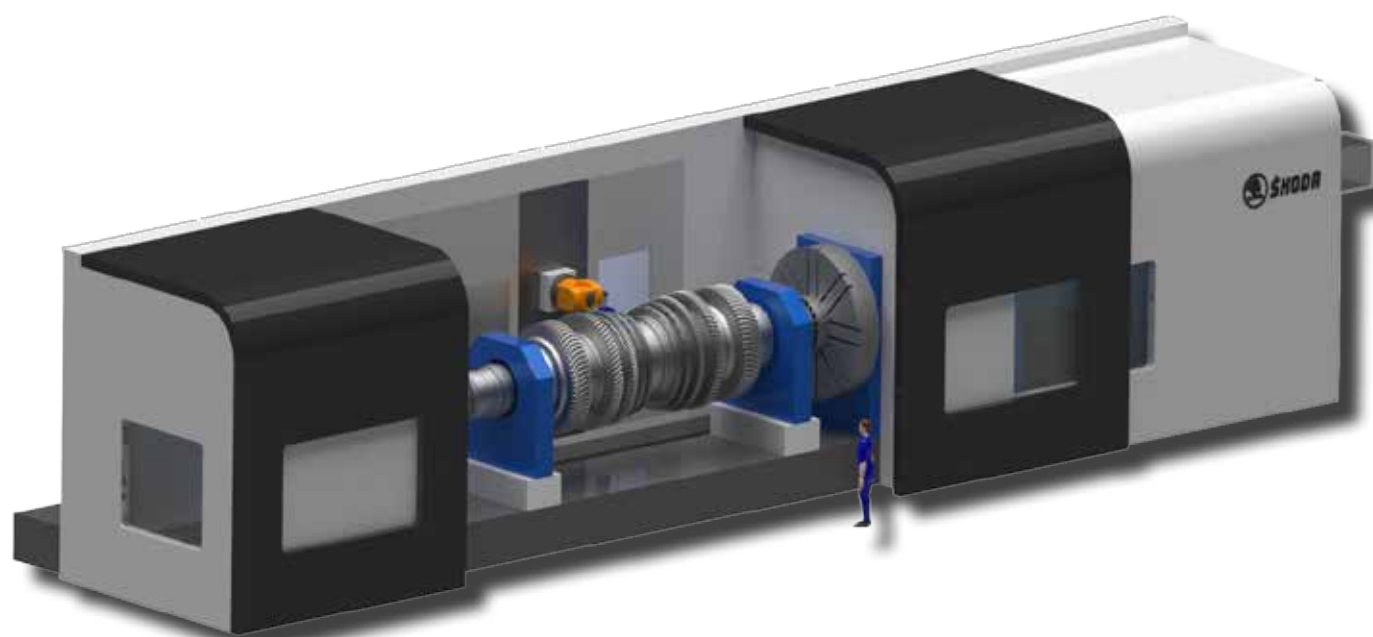

MULTIFUNKČNÍ SOUSTRUŽNICKO-FRÉZOVACÍ CENTRA

S 150 MT

S 200 MT

S 320 MT

S 500 MT

Oběžný průměr nad suportem	(mm)	1500	2000	3200	5000
Otáčky vřetena	(min ⁻¹)	700	400	300	200
Max. hmotnost obrobku	(kg)	32000	70000	160000	250000
Délka obrobku	(mm)	4000 ÷ 10000	4000 ÷ 10000	5000 ÷ 15000	5000 ÷ 15000
Výkon hlavního motoru	(kW)	71	95	190	190

